

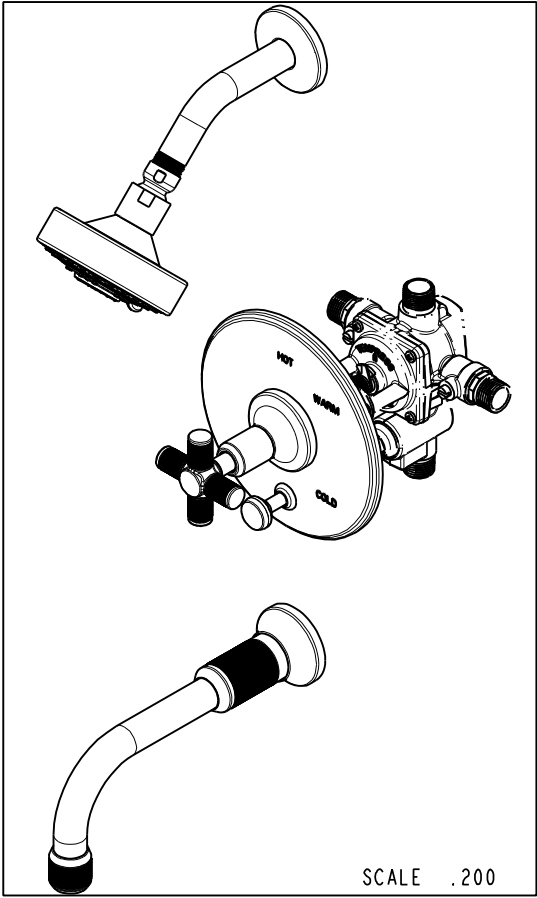

PN: 1-595  
SOLD SEPARATELY



SCALE .200

<b>BRASSTECH</b>		2001 E. CARNEGIE AVE. SANTA ANA, CA 92705 (949) 417-5207	
DWG NO.	3-3262BP		REV A
SCALE .300	REF. -	SHEET 2 OF 3	

NOTE:

 CUT ALL THREAD 1.00" SHORTER THAN STEM.

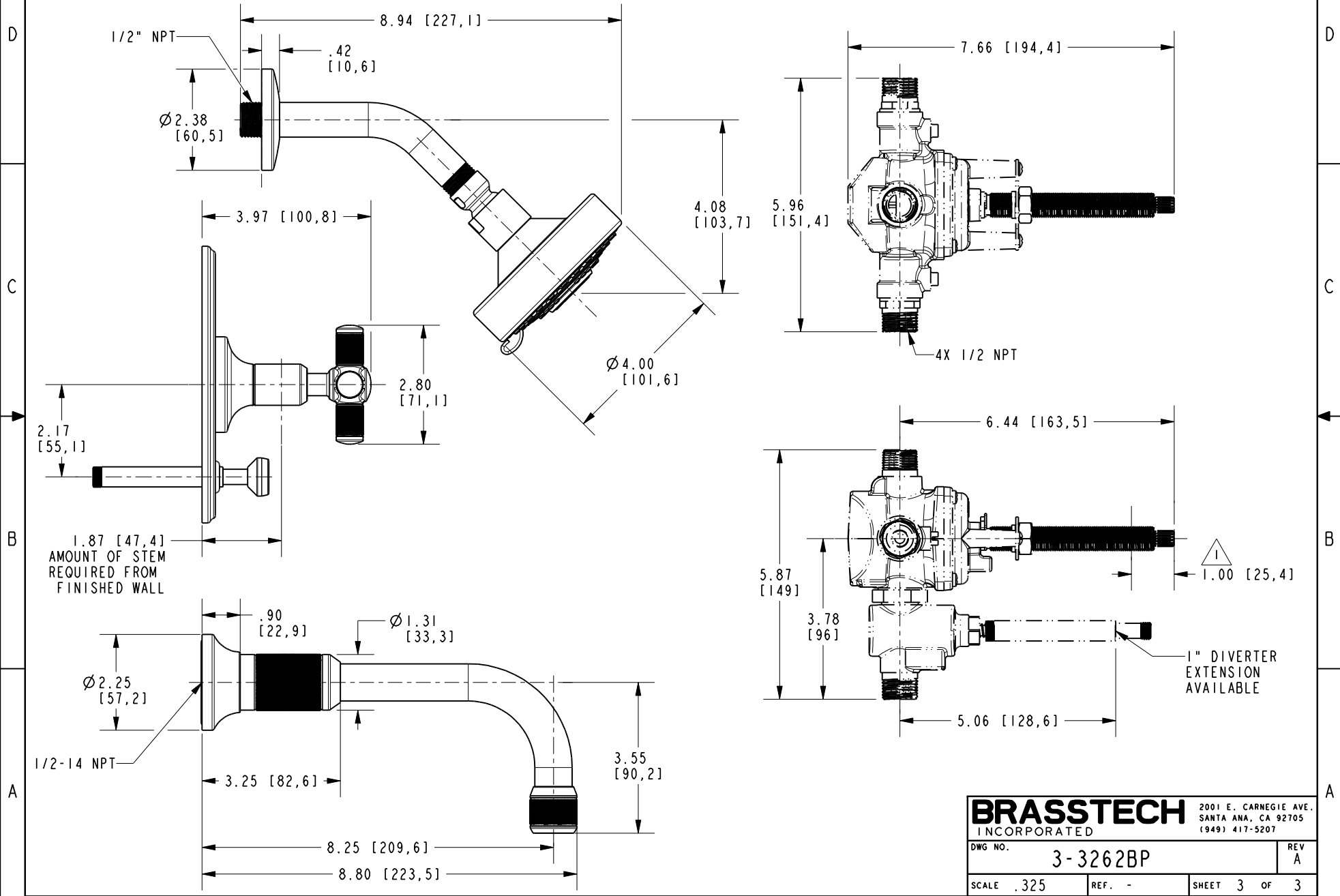

<b>BRASSTECH</b>		2001 E. CARNEGIE AVE. SANTA ANA, CA 92705 (949) 417-5207	
DWG NO.	3-3262BP		REV A
SCALE .325	REF. -	SHEET 3 OF 3	